

MTL4541/S – MTL5541/S

REPEATER POWER SUPPLY

4/20mA, HART®, 2- or 3-wire transmitters

The MTLx541 provides a fully-floating dc supply for energising a conventional 2- or 3-wire 4/20mA transmitter, which is located in a hazardous area, and repeats the current in another floating circuit to drive a safe-area load. For HART 2-wire transmitters, the unit allows bi-directional communications signals superimposed on the 4/20mA loop current. Alternatively, the MTLx541S acts as a current sink for a safe-area connection rather than driving a current into the load. Separately powered current sources, such as 4-wire transmitters, can be connected but will not support HART communication.

SPECIFICATION

See also common specification



Number of channels

One

Location of transmitter

Zone 0, IIC, T4–6 hazardous area if suitably certified
Div. 1, Group A hazardous location

Safe-area output

Signal range: 4 to 20mA
Under/over-range: 0 to 24mA
Safe-area load resistance (MTLx541)
@ 24mA: 0 to 360Ω
@ 20mA: 0 to 450Ω
Safe-area load (MTLx541S)
Current sink: 600Ω max.
Maximum voltage source: 24V dc
Safe-area circuit output resistance: > 1MΩ

Safe-area circuit ripple

< 50μA peak-to-peak

Hazardous-area input

Signal range: 0 to 24mA (including over-range)
Transmitter voltage: 16.5V at 20mA

Transfer accuracy at 20°C

Better than 15μA

Temperature drift

< 0.8μA/°C

Response time

Settles to within 10% of final value within 50μs

Communications supported

HART (terminals 1 & 2 only)

MTL4541 / MTL4541S

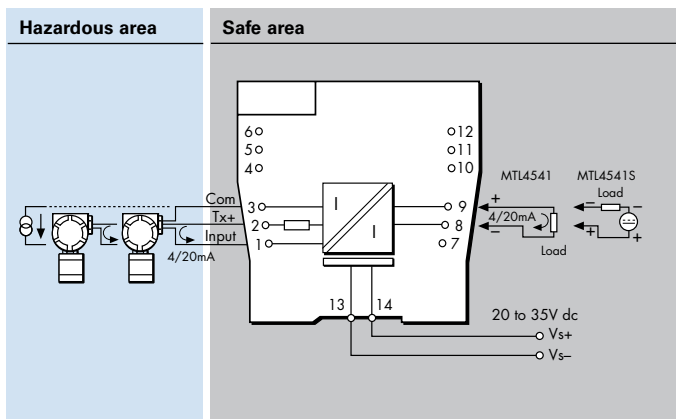

MTL5541 / MTL5541S

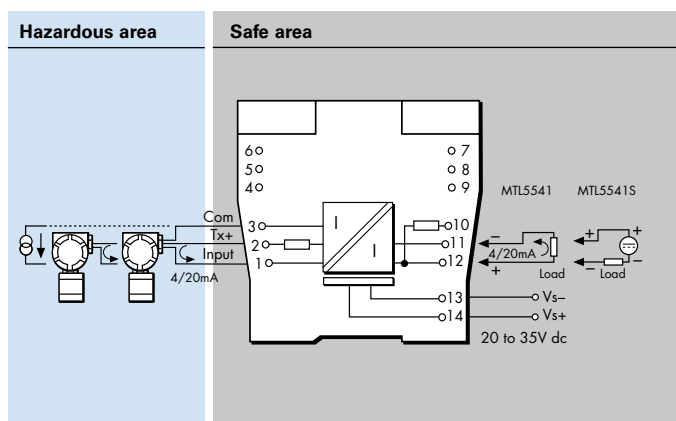

LED indicator

Green: power indication

Maximum current consumption (with 20mA signal)

51mA at 24V

Power dissipation within unit (with 20mA signal)

MTLx541 0.7W @ 24V dc
MTLx541S 1.0W @ 24V dc

Safety description

Terminals 2 to 1 and 3:

$U_o=28V$ $I_o=93mA$ $P_o=651mW$ $U_m=253V$ rms or dc

Terminals 1 to 3:

Simple apparatus $\leq 1.5V$, $\leq 0.1A$ and $\leq 25mW$; can be connected without further certification into any IS loop with an open-circuit voltage $< 28V$



SIL capable

These models have been assessed for use in IEC 61508 functional safety applications. SIL3 capable for a single device (HFT=0) See data on MTL web site and refer to the safety manual.



Powering Business Worldwide

Eaton Electric Limited,

Great Marlings, Butterfield, Luton
Beds, LU2 8DL, UK.
Tel: + 44 (0)1582 723633 Fax: + 44 (0)1582 422283
E-mail: mtlenquiry@eaton.com
www.mtl-inst.com

© 2018 Eaton
All Rights Reserved
Publication No.
EPSx541/S Rev7 150817

EUROPE (EMEA):

+44 (0)1582 723633 mtlenquiry@eaton.com

THE AMERICAS:

+1 800 835 7075 mtl-us-info@eaton.com

ASIA-PACIFIC:

+65 6 645 9888 sales.mtlsing@eaton.com

The given data is only intended as a product description and should not be regarded as a legal warranty of properties or guarantee.

In the interest of further technical developments, we reserve the right to make design changes.