

Weatherproof Telephone InduTel – InduTel LED

Telephone for indoor and outdoor applications with protective door



Overview

The telephone InduTel by FHF is characterized by an elegant design for indoor uses as well as a high resistance for uses in outdoor facilities with non-explosive environments.

The InduTel is the ideal device for a number of different operation sites – no matter if exposed to seawater, high humidity or extensive mechanical strain.

Thanks to the protective door, the handset and keypad are always perfectly protected against contamination.

InduTel LED: In case of an incoming call the handset rest starts blinking. If the handset is lifted up the illumination will switch to the keypad.

Features

- Protection class IP 66 according to IEC60529
- ambient temperature -40 °C to +55 °C
- Protective door in yellow, red or transparent
- PIN for change of settings
- Connection for secondary sounder
- Optical call indication

Technical data	
Supply voltage	24 ... 66 VDC
Supply current	19 ... 100 mA
AC ringing voltage	30 ... 90 VAC
Ringing signal frequency	16 ... 68 Hz
Sounder input impedance	≥ 6.0 kΩ at 25 Hz ≥ 3.5 kΩ at 50 Hz
Enquiry key (flash)	Only for DTMF 80 ms, 120 ms, 600 ms
Dialling procedure	
DTMF	Frequencies according to ITU-T Q.23
PD	Tone duration unlimited or 90 ms Pulse/Pause ratio 1.5:1 (60/40 ms) or 2:1 (66.7/33.3 ms)
Ringing volume	With open housing cover approx. 90 dB(A) in 1 m distance With closed housing cover approx. 65 dB(A) in 1 m distance
Connection for secondary sounder	
Wiring	W, W1
Ringing volume	With open housing cover approx. 90 dB(A) in 1 m distance With closed housing cover approx. 65 dB(A) in 1 m distance
Operating position	
Receiver	Vertical wall mounting
Receiver	
Mouthpiece	Elektret microphone
Earpiece	Dynamic capsule
Connections	Single-wire or multi-wire up to 2.5 mm ²
Housing	
Material	Polycarbonat
Hight x weight x depth	330 x 237 x 110 mm
Weight	2.3 kg (telephone incl. telephone bracket)
Labelling	
Connection cable	TCP/La – TCP/Lb (TCP: Terminal Connection Point)
Ambient temperature	
Operation	-40 °C ... +55 °C
Transport	-40 °C ... +70 °C
Cable glands	2x M16 x 1.5 For cable diameters 5-9 mm

General arrangement (all dimensions in mm)

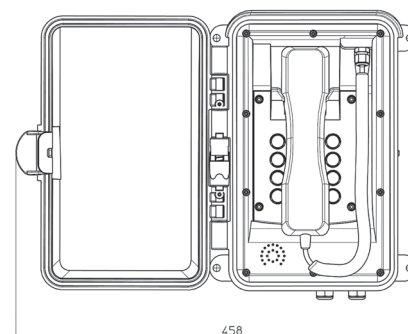
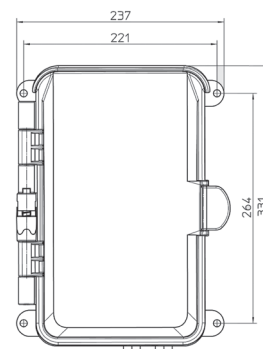
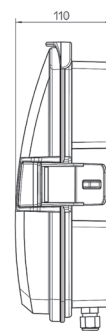

Ordering requirements

Type	Designation	Colour	Art.-No.
InduTel	Wall telephone with protective door	Yellow	FHF 112 645 01
InduTel	Wall telephone with protective door	Red	FHF 112 645 01 02
InduTel	Wall telephone with protective door, w/o keypad	Yellow	FHF 112 645 02
InduTel	Wall telephone with protective door, w/o keypad	Red	FHF 112 645 02 02
InduTel	Wall telephone with protective door, transparent	Yellow	FHF 112 645 04
InduTel	Wall telephone with protective door, transparent	Red	FHF 112 645 04 02
InduTel	Wall telephone with protective door, transparent, w/o keypad	Yellow	FHF 112 645 05
InduTel	Wall telephone with protective door, transparent, w/o keypad	Red	FHF 112 645 05 02
InduTel LED	Wall telephone with protective door, transparent, with optical call indication	Yellow	FHF 112 645 06
InduTel LED	Wall telephone with protective door, transparent, with optical call indication	Red	FHF 112 645 06 02