

# MTL4544D – MTL5544D REPEATER POWER SUPPLY

single channel, 4/20mA, HART®  
for 2- or 3-wire transmitters, two outputs

The MTLx544D provides a fully-floating dc supply for energising a conventional 2- or 3-wire 4/20mA transmitter located in a hazardous area, and repeats the current in other circuits to drive two safe-area loads. For HART 2-wire transmitters, the unit allows bi-directional transmission of digital communication signals superimposed on the 4/20mA loop current. Separately powered current sources, such as 4-wire transmitters, can be connected but will not support HART communication.

## SPECIFICATION

See also common specification



### Number of channels

One

### Location of transmitter

Zone 0, IIC, T4–6 hazardous area if suitably certified  
Div. 1, Group A hazardous location

### Safe-area output

Signal range: 4 to 20mA  
Under/over-range: 0 to 24mA  
Safe-area load resistance  
@ 24mA: 0 to 360Ω  
@ 20mA: 0 to 450Ω  
Safe-area circuit output resistance: > 1MΩ

### Safe-area circuit ripple

< 50μA peak-to-peak

### Hazardous-area input

Signal range: 0 to 24mA (including over-range)  
Transmitter voltage: 16.5V at 20mA

### Transfer accuracy at 20°C

Better than 15μA

### Temperature drift

< 0.8μA/°C

### Response time

Settles to within 10% of final value within 50μs

### Communications supported

HART (terminals 1 & 2, output Ch 1 only)

## MTL4544D

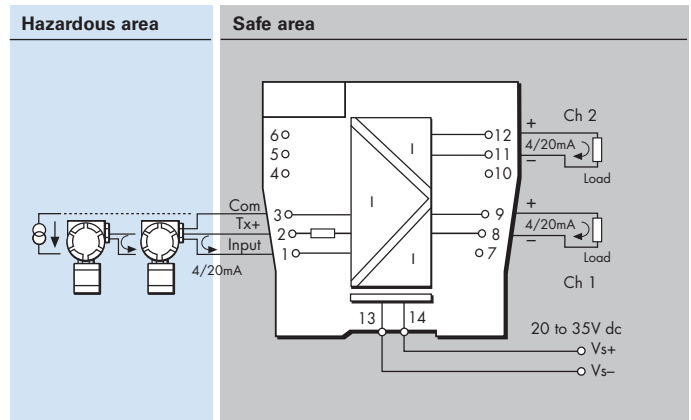

## MTL5544D

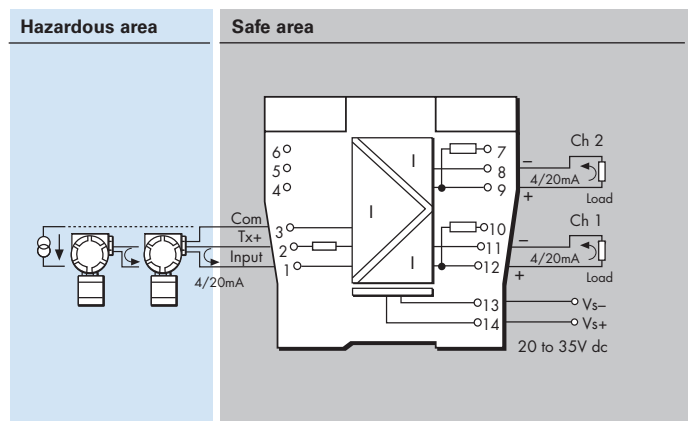

### LED indicator

Green: power indication

### Maximum current consumption (with 20mA signals)

96mA at 24V dc

### Power dissipation within unit (with 20mA signals)

1.4W @ 24V dc

### Safety description

Terminals 2 to 1 and 3:

$U_o=28V$   $I_o=93mA$   $P_o=0.65W$   $U_m=253V$  rms or dc

Terminals 1 to 3:

Simple apparatus  $\leq 1.5V$ ,  $\leq 0.1A$  and  $\leq 25mW$ ; can be connected without further certification into any IS loop with an open-circuit voltage <28V



### SIL capable

These models have been assessed for use in IEC 61508 functional safety applications.

SIL3 capable for a single device (HFT=0)

See data on MTL web site and refer to the safety manual.

The given data is only intended as a product description and should not be regarded as a legal warranty of properties or guarantee. In the interest of further technical developments, we reserve the right to make design changes.



Powering Business Worldwide

### Eaton Electric Limited,

Great Marlings, Butterfield, Luton  
Beds, LU2 8DL, UK.  
Tel: + 44 (0)1582 723633 Fax: + 44 (0)1582 422283  
E-mail: mtlenquiry@eaton.com  
www.eaton.com

© 2025 Eaton  
All Rights Reserved  
Publication No.  
EPSx544D Rev 9 230524

### EUROPE (EMEA):

+44 (0)1582 723633 mtlenquiry@eaton.com

### THE AMERICAS:

+1 800 835 7075 mt-us-info@eaton.com

### ASIA-PACIFIC:

+65 6 645 9888 sales.mtlsing@eaton.com